

System Overview

The Telesis[®] TMP1700/470 PINSTAMP[®] marking system permanently prints messages into a variety of materials such as steel, aluminum, and plastic. A hardened pin is pneumatically accelerated to indent dot matrix characters into the item being marked. The shape, size, density, and location of characters are determined by the user through the system software. The marking head moves the pin cartridge through X- and Y-axis motions to reach the correct position for each dot of the characters to be marked. The system software automatically controls pin extension and retraction to mark the message.

The system is compliant with UL, CSA, CE, and RoHS specifications.

TMP1700 Marking Head includes the mechanical motion components to position the marking pin at precise X/Y positions and the pneumatic components to drive the marking pin from, and return the pin to, the pin cartridge.

The floating pin design permits high quality, consistent marks on irregular, slightly curved surfaces. It also accommodates applications where marking surfaces cannot be positioned at a consistent distance from the marker.

The TMP1700 marking head is an X/Y-traversing mechanism. Using two stepper motor drives, it accurately and rapidly positions the pin at coordinate-defined locations in marking window within .001" (.025 mm). The TMP1700 accommodates the rigorous dynamics of impacting, rebounding, and rapid positioning of the marking pin through a system of rigid rails and ball bearing saddles, timing belts, and direct-drive, toothed pulleys.

The internal mechanism is protected from debris by an integral shield. Three stainless steel panels slide against one another, constrained by the cartridge and the high-impact ABS cover, to

prevent debris from entering the marking head. A flexible, oil-resistant fabric boot is also available for applications requiring additional protection, especially against liquid sprays and mists.

Marker Cable, pre-wired to the marking head, connects the marker to the controller. The highly flexible cable is 4m (13 ft.) long. Optional extension cables are available for greater distances.

Pin Cartridges, machined from engineered plastic materials, offer long life with little maintenance. Clasps are used to attach the pin cartridge to the marking head for easy cleaning and pin replacement.

Marking Pins for the TMP1700 include the 25L-, 25XL-, 150S, 150SA-series and the 10MP MicroPin[™]. Refer to the marking head installation drawing for pin stroke (pin extension) dimensions. Refer to the marking depth tables for pin cone angles and depths.

Filter/Regulator Unit includes two regulators with pressure gauges to control the drive air and return air. The first regulator contains a filter to help remove contaminants from the supply air. Two air lines connect the regulated air to the marking head. Drive air fires the impact pin; return air pushes it back into the cartridge. The standard air lines are 12 ft. (3.6 m) long made of 1/4" tubing.

TMC470 Controller contains an integrated keyboard with an LCD display. It provides a text-only operator interface and allows full operational control of the TMP1700 marking head. The back panel provides the electrical interface for connecting to optional, remote I/O sources. Refer to *TMC470 Controller Specifications* for details.

Optional System Computer. The TMC470 Controller may be connected to a PC that runs the Merlin[®] III Visual Design Software. The PC may be supplied by Telesis or by the customer. Refer to *PC-based Merlin III Software* and *TCP/IP Interface* for details.

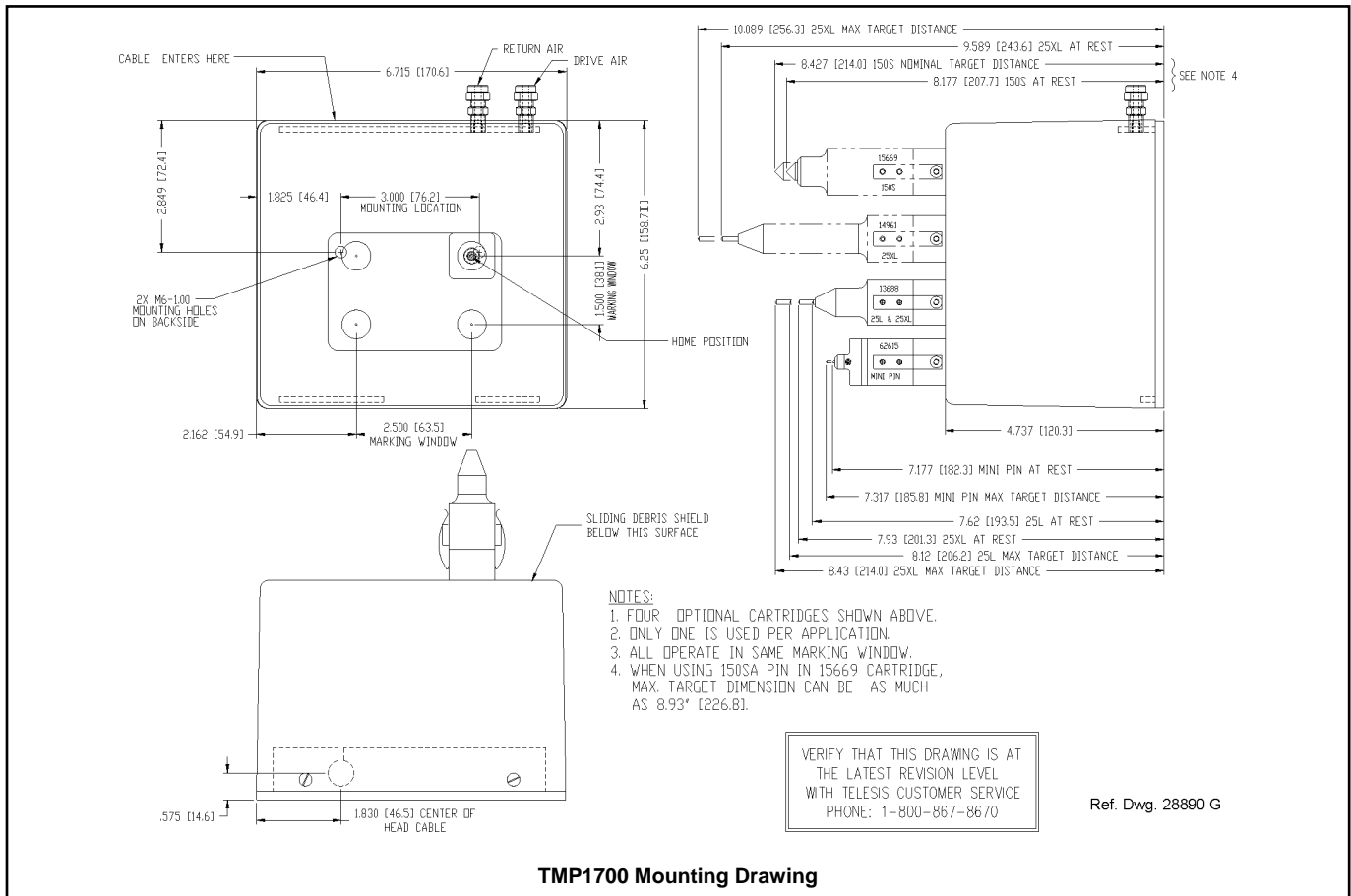

System Setup

When designing a fixture, allow for 3-axis adjustment to aid in horizontal, vertical, and lateral alignment of the marking head.

- Mount marking head to optional tool post assembly (or other suitable fixture) using two M6 bolts. **Mounting bolts must not extend into marking head more than 5/8" (15 mm).**
- Mount filter/regulator assembly within 12 ft. (3.6m) of marker.
- Connect drive air and return air lines to the marking head.
- Connect supply air to input port on filter/regulator assembly.
- Locate controller as close as practical to marking head. Standard marker cable length is 4 m (13 ft.).
- Install the controller as a table-top, wall-mounted, panel-mounted, or enclosure-mounted unit, as applicable.
- Ensure controller power switch is OFF.
- Connect marker cable to controller.
- Connect power cable to controller.
- (optional) For systems that connect to a PC running the Merlin III Visual Design Software:
 - Ensure PC power switch is OFF.
 - Connect cable to controller Ethernet Port and to PC.
 - Connect power cable to PC.
 - Position PC power switch to ON.
 - (customer-supplied PC) Install marking system software.
- Position controller power switch to ON.
- Start marking system software.
- Adjust pin stroke, drive air, and return air for impact depth.

Note: The TMC470 is not a sealed unit. Protect it from potentially damaging conditions and contaminants. Do not block vents in bottom of case. Ensure the marking system is electrically isolated from any devices that may generate extreme electromagnetic interference (EMI).

System Options

- Oil Resistant Fabric Boot
- Marking Head Extension Cables
- Tool Post Assembly
- Auxiliary Axis Driver Board Kit
- Motorized Z-axis Tool Post with Programmable Travel
- Motorized Theta-axis with Programmable Rotary Drive Unit
- TMC470 Controller Wall-mounting Bracket Kit
- TMC470 Controller Panel-mounting Bezel/Bracket Kit
- TMC470N NEMA® Enclosure
- Bar Code Scanner or Bar Code Wand with Cable
- Foot Switch (Start Print) or Pushbutton Station (Start/Abort)
- Backup Utility Software
- Upgrade Utility Software
- Logo/Font Generator Software
- Merlin III Visual Design Software
- System Computer (to run the Merlin III software)

TMP1700 Marking Head

Specifications. The TMP1700 marking head specifications are subject to change without prior notice.

DIMENSIONS	<i>refer to TMP1700 Installation Drawing</i>
WEIGHT	6.4 lb. (2.9 kg)
OPERATING TEMP.	32° to 122° F (0° to 50° C), non-condensing
AIR SUPPLY	Clean and dry, 60 to 120 psig (4.2 to 8.3 bars)
AIR CONSUMPTION	.04 SCFM (idle) 0.6 SCFM (marking)
MARKING AREA	2.5 x 1.5" (63 x 38 mm)
PIN TYPES	10MP-, 25L-, 25XL-, 150S, or 150SA-series
PIN MATERIAL	Carbide (10MP-series MicroPin™) Powdered metal or stainless steel with diamond tip or carbide (25L-, 25XL-series) Powdered metal or tool steel with carbide tip (150S-, 150SA-series)

Marking Characteristics. The TMP1700 can produce characters as small as .030" (.76mm), printed at any angle within the marking window. Printing resolutions range from 10 dots per inch to 200 dots per inch for an engraved look. The depth of mark can be adjusted over a significant range by adjusting the pin stroke and, to a lesser extent, by adjusting the drive air pressure.

Marking Speeds. Generally, the system will mark four characters per second (using 5x7 font, .125" [3 mm] high characters). Speeds will vary slightly depending on the selected character size, style, and dot density. Specific times can be verified by a Telesis representative.

Pin Life. Pin life depends largely on the type of material being marked, how hard or abrasive it is, and the required marking depth. On typical metals with a hardness of Rockwell Rb47, marking at a depth of .005" (.127 mm), powdered steel pins average about 3 million impressions before needing sharpened; carbide pins average approximately 9 million impressions. If carbide pins are used, marking times will increase by approximately 25% due to the increased weight of the pins.

Marking Noise. When marking cold-rolled steel strips at 50% duty cycle, the noise level of the TMP1700 Marking System has been measured at 74.6 dB, using the "time weighted average" approach (average sound exposure over an 8 hour period). It is expected that as the duty cycle rises, the time weighted average will rise also. Typical applications average around 20%-30% duty cycle where the sound pressure level would not exceed 70 dB (A).

Noise-level Tests have been carried out under controlled conditions imitating as closely as possible predicted normal operation.

Conditions such as rigidity of the work piece, material, setting of the machine, ambient noise, etc. may vary when in operational use and would alter the actual noise level.

Despite detailed guidance notes provided with each machine, these conditions would be out of the control of Telesis and must remain the responsibility of the end user to conduct their own tests to establish safe working levels of use.

Marking Depth. The following tables provide sample marking depths. Drive air was set at 80 psi (5.5 bars); return air was set at 20 psi (1.4 bars); pin stroke was set to the maximum allowable distance for each pin type to achieve the maximum depth of mark.

Marking Depths – Type 25L & 25XL Powdered-Metal Pins

MATERIAL (HARDNESS)	22° CONE	30° CONE	45° CONE	60° CONE
Aluminum (Rb3)	.005 in. .127 mm	.007 in. .178 mm	.011 in. .279 mm	.016 in. .406 mm
Brass (Rb18)	.003 in. .076 mm	.005 in. .127 mm	.009 in. .229 mm	.012 in. .305 mm
Cold Rolled Steel (Rc18)	.003 in. .076 mm	.005 in. .127 mm	.008 in. .203 mm	.012 in. .305 mm

Marking Depths – Type 25L & 25XL Carbide Pins

MATERIAL (HARDNESS)	22° CONE	30° CONE	45° CONE	60° CONE
Aluminum (Rb3)	.006 in. .152 mm	.007 in. .178 mm	.010 in. .254 mm	.011 in. .279 mm
Brass (Rb18)	.005 in. .127 mm	.007 in. .178 mm	.008 in. .203 mm	.009 in. .229 mm
Cold Rolled Steel (Rc18)	.004 in. .101 mm	.005 in. .127 mm	.007 in. .178 mm	.009 in. .229 mm

Marking Depths – Type 150S Pins

MATERIAL (HARDNESS)	22° CONE	30° CONE	45° CONE	60° CONE
Aluminum (Rb3)	N/A	.008 in. .203 mm	.012 in. .305 mm	.018 in. .457 mm
Brass (Rb18)	N/A	.007 in. .178 mm	.010 in. .254 mm	.017 in. .432 mm
Cold Rolled Steel (Rc18)	N/A	.006 in. .152 mm	.008 in. .203 mm	.013 in. .330 mm

Marking Depths – Type 150SA Pins

MATERIAL (HARDNESS)	22° CONE	30° CONE	45° CONE	60° CONE
Aluminum (Rb3)	N/A	.008 in. .203 mm	.012 in. .305 mm	N/A
Brass (Rb18)	N/A	.007 in. .178 mm	.010 in. .254 mm	N/A
Cold Rolled Steel (Rc18)	N/A	.006 in. .152 mm	.008 in. .203 mm	N/A

TMP1700 Marking Head (continued)

Vibration Data. Vibration tests were performed under controlled conditions imitating, as closely as possible, typical normal operation.

Conditions such as rigidity of the work piece, material, setting of the machine, etc. may vary in actual operational use and would alter the actual vibration level. Despite detailed guidance instructions provided with each machine, such conditions are beyond the control of Telesis and must remain the responsibility of the end user. Accordingly, you should conduct your own tests to establish safe working levels of use.

The vibration tests were conducted using the following parameters:

- DRIVE AIR PRESSURE:** 4.08 bars (60 psi)
- RETURN AIR PRESSURE:** 1.36 bars (20 psi)
- PIN STROKE:** 8 mm (.31 in)
- MARKING BASE:** 20 mm (.79 in) thick steel
- MARKING SURFACES:** 2 mm (.08 in) thick steel plate
4 mm (.16 in) thick aluminum plate
- MARKING MODE:** Dot
- TEXT MARKED:** TELESIS
(11x16 font, 5mm [.20 in] characters)
HHHEEE000888
(5x7 font, 3mm [.12 in] characters)

The following test results reflect the worst-case scenarios under the given test conditions.

Steel Marking Surface			
Pin	VM	T _(EAV)	T _(ELV)
25C	0.4 m/s ²	more than 24 hr	more than 24 hr
150SA	0.8 m/s ²	more than 24 hr	more than 24 hr
Aluminum Marking Surface			
Pin	VM	T _(EAV)	T _(ELV)
25C	0.6 m/s ²	more than 24 hr	more than 24 hr
150SA	1.2 m/s ²	more than 24 hr	more than 24 hr

where:

- VM** = hand/arm vibration magnitude.
- T_(EAV)** = time to reach the *Exposure Action Value* based on continuous marking.
- T_(ELV)** = time to reach the *Exposure Limit Value* based on continuous marking.

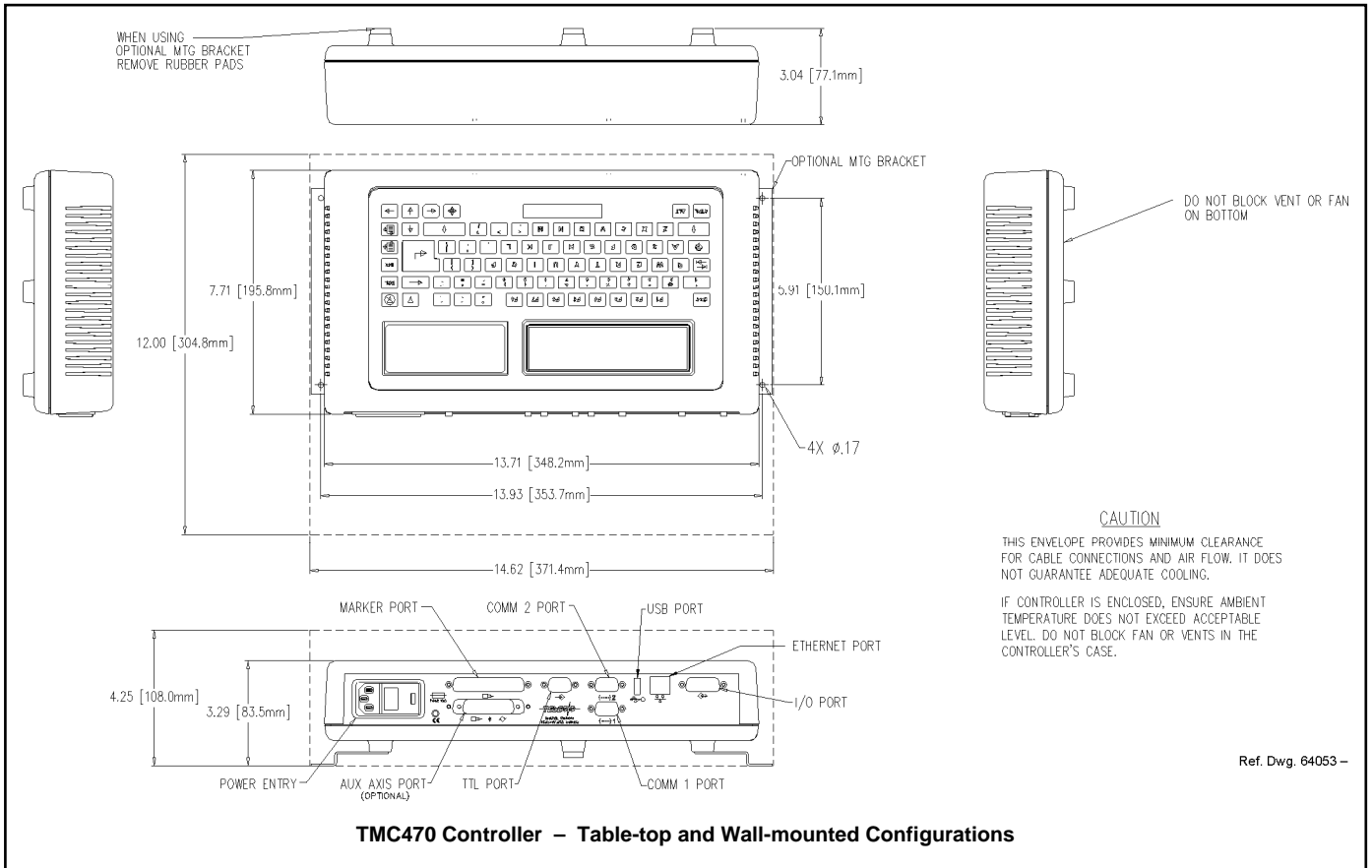

TMC470 Controller

The TMC470 controller may be installed as a table-top unit, a wall-mounted unit, a panel-mounted unit, or an enclosure-mounted unit. All configurations provide features and connectivity for external communications. Differences occur only in the mounting configuration.

TMC470 Specifications. The TMC470 Controller specifications are subject to change without prior notice.

COMPLIANCE	CE, RoHS
CONFIGURATIONS	Table-top, Wall-mounted, Panel-mounted, or Enclosure-mounted
RATING	NEMA 1 (I.P. 30) table-top or wall-mounted NEMA 12 (I.P. 65) panel-mounted using appropriate customer-supplied panel NEMA 12 (I.P. 65) enclosure-mounted using Telesis-supplied TMC470N enclosure
DIMENSIONS	refer to the TMC470 Mounting Drawings
WEIGHT	3.69 lb. (1.68 kg) controller only 3.90 lb. (1.77 kg) with wall-mount kit 5.52 lb. (2.51 kg) with panel-mount kit 28.1 lb. (12.77 kg) with TMC470N enclosure

TMC470 Specifications (continued)

OP. TEMPERATURE	32° to 122° F (0° to 50°C)
OP. HUMIDITY	10% to 80% non-condensing
COOLING	Internal, thermostatically-controlled fan
POWER REQ'MENTS	95 to 250 VAC, 2 amps, 50-60 Hz, single phase
COMMUNICATIONS	TTL, Discrete I/O, RS232, RS485, TCP/IP, and USB (data backup/transfer)
INPUT SIGNALS	Twelve (12) total 8 dedicated, 1 programmable, 3 available 10 VDC (minimum voltage) 30 VDC (maximum voltage) 12 to 24 VDC (nominal voltage) 2.3 mA @ 12VDC; 4.9 mA @ 24VDC (nominal current)
OUTPUT SIGNALS	Six (6) total 4 dedicated, 2 available 0.25 amps (maximum current) 0.50 ohms (maximum On resistance) 40 VDC (maximum line voltage) 12 to 24 VDC (nominal line voltage)

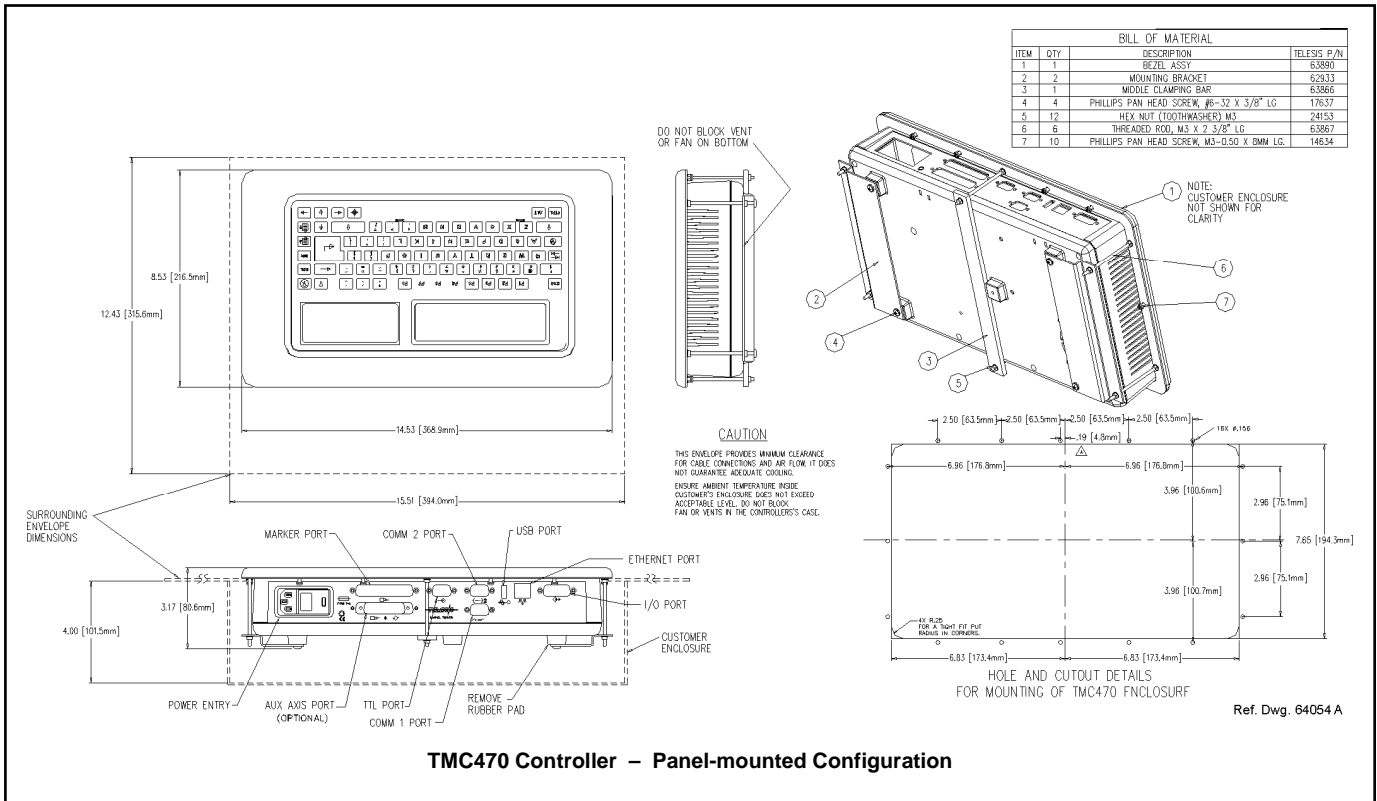

Environmental Considerations. The following environmental considerations must be taken into account when installing the TMC470 Controller.

Contaminants. The vented TMC470 is rated NEMA 1 (IP30) and contains a thermostatically-controlled, variable speed fan. Accordingly, in environments where solid and/or liquid contaminants are present, the possibility exists that these contaminants can be drawn into the TMC470 controller and possibly result in failure. For that reason, in these types of environments, the controller must be located in a sealed industrial enclosure. To facilitate such installations, Telesis offers an optional panel mounting kit for use with an appropriate customer-supplied panel or enclosure. Telesis also offers an optional TMC470N NEMA 12 (I.P. 65) enclosure in which the controller can be mounted.

EMI Susceptibility. Although the system has been found to be in compliance with pertinent susceptibility standards, care should be taken when installing near welders and other extreme generators of electromagnetic interference (EMI). Particular care should be taken to ensure welder currents are not injected through the marking head chassis. The marking head chassis is connected to the electrical service earth ground through the marking head cable. The marking head should be electrically isolated from all surfaces which could become part of a welder current path.

TMC470-based System Software. The system software is permanently installed in the controller. It provides the user interface for the operator to control the marker. The software also provides a library for storing, loading, and editing user-defined patterns. Patterns are files stored in the controller's memory. Depending on the size of the pattern files, the controller can store up to 200 patterns. Each pattern contains one or more fields; each field defines a single object. Printable objects may be created to define text strings, arc-text strings, geometric shapes, graphics, and machine-readable data matrix symbols. Non-printable objects may be defined to specific commands to the marker (e.g., Pause, Go to, Input, or Output). Printable text fields may include alphanumeric characters, symbols, and special message flags. Message flags automatically insert data into the text string, such as serial numbers, times, dates and user-defined codes.

PC-based Merlin III Visual Design Software. Optionally, the TMC470 Controller may be connected to a PC that runs the Telesis Merlin III Visual Design Software. The software is a 32-bit Windows® based WYSIWYG application that provides a graphical user interface to make pattern design quick and easy. Just "click and drag" for immediate adjustment to field size, location, or orientation. The Merlin III software includes tools to create and edit text, arc text, rectangles, circles, ellipses, and lines. Existing DXF files can also be imported for marking.

After downloading patterns to the controller, the PC can be disconnected from the controller to allow the TMC470 to control marking operations. Optionally, the PC may remain connected to the controller and allow the Merlin III software to fully control the marking system.

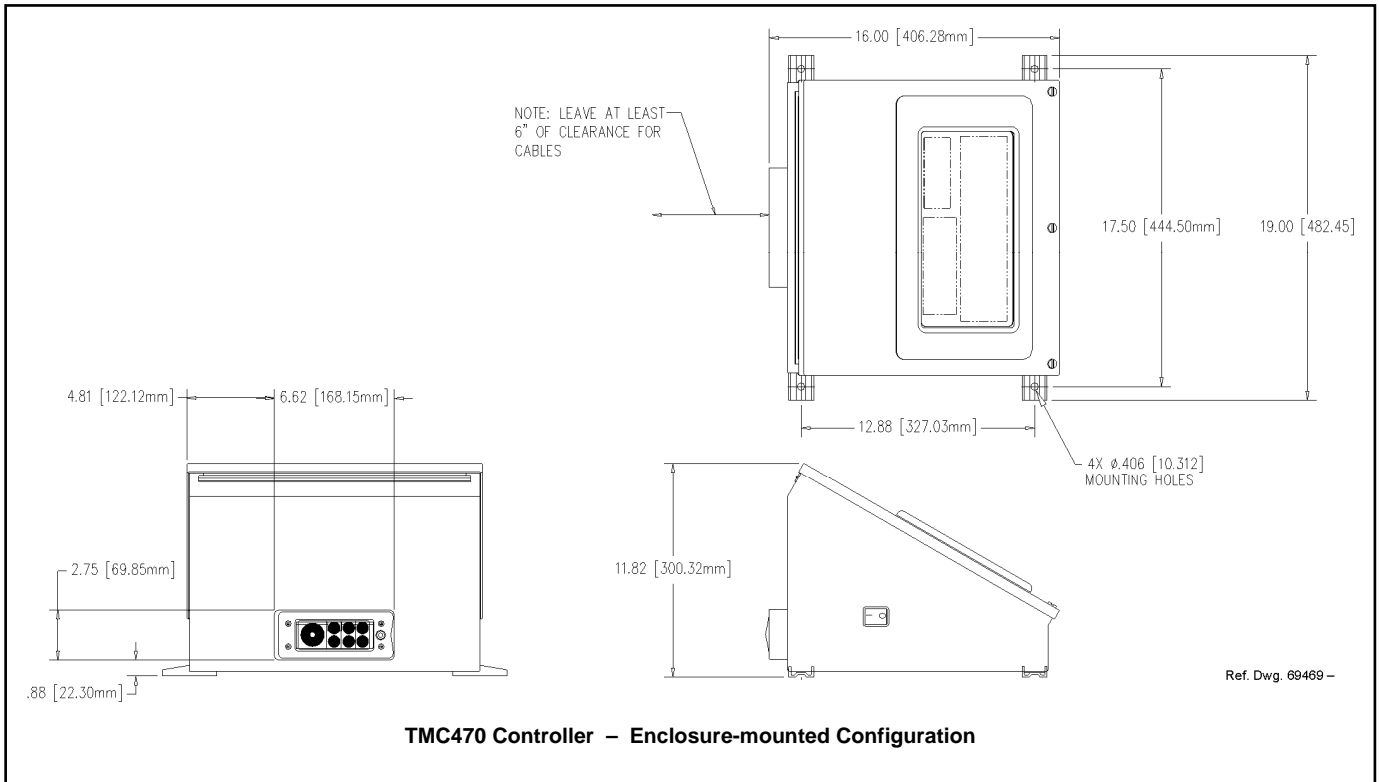

Interface Panel. The back panel of the controller provides various ports for connecting the marker, host computers, logic controllers, optional accessories, and remote I/O devices. See below.

- **Serial Interface.** The Comm 1 and Comm 2 Ports allow connection to remote serial devices such as a host computer or a bar code scanner. See *Host Communications* for details.
- **Discrete I/O Interface.** The I/O Port allows you to connect a Programmable Logic Controller (PLC) or other DC I/O source for remotely controlling marker operations. See *Discrete I/O Controls* for details.
- **TTL Interface.** The TTL Port allows the system to connect with a simple contact closure circuit such as a remote push button station or foot pedal switch. These types of devices can remotely control Start Print and Stop Print operations.
- **TCP/IP Interface.** The Ethernet Port typically connects to a PC over a local area network (LAN). It allows you to define the controller as a client or a server socket using Telesis Extended Protocol. See *Host Communications* for details.
- **USB Interface.** The USB Port allows you to connect a memory stick/flash drive for pattern storage/retrieval and for software upgrades.
- **(optional) Auxiliary Axis Interface.** The Auxiliary Axis Port allows the system to connect with up to four optional motion devices such as motorized tool posts, rotational drive units, and linear slides or actuators.

Discrete I/O Controls

The TMC470 is configured for 12 VDC to 24 VDC I/O only and is provided to connect a PLC or other DC I/O source. The I/O Port allows you to remotely select and load patterns, start printing, stop printing, place the marker online, and monitor the system output signals. Cable connectors and connector pins are supplied with the controller for constructing appropriate interface cables.

Input Signals. These input signals provide the following controls:

INPUT COMM	For all inputs (+ or – supply)
START PRINT	Begins print cycle
STOP	Stops the print cycle
SEL_0 THRU _6 *	Remotely selects and loads pattern files
SPARE_1, 2, 3	Three (3) spares for custom applications

* Optionally, the SEL_6 signal may be programmed to place the marker online.

Output Signals. These output signals indicate the following states:

OUTPUT COMM	For all outputs (+ or – supply)
DONE	Print cycle is complete
READY	System ready for message or start print
PAUSED	System paused (waiting timeout or command)
NO FAULT	System status (normal or fault detected)
SPARE_1, 2	Two (2) spares for custom applications

Host Communications

The marking system software allows you to configure communication parameters to transmit and receive data to and from a host computer. To provide maximum integration flexibility, the system software supports RS-232 and RS-485 serial interfaces and Ethernet TCP/IP interfaces. The system software also provides two protocol choices: Programmable Protocol and Extended Protocol.

RS-232 Interface. The serial (RS-232) communications interface is most often used with remote devices such as host computers, terminals, or bar code scanners. The Comm 1 RS-232 interface supports both Telesis Extended Protocol and Telesis Programmable Protocol. The Comm 2 RS-232 interface supports only Telesis Programmable Protocol.

RS-485 Interface. The RS-485 interface is normally used for long transmission distances or multi-drop networks of up to 31 TMC470 controllers. You must use Telesis Extended Protocol with the RS-485 interface.

The following describes the serial data character format on all transmissions to and from the TMC470 Controller.

- Asynchronous
- 1200, 2400, 4800, 9600, 19200, 38400, or 115200 Baud
- 1 or 2 Stop Bits
- 7 or 8 Data Bits
- None, Even or Odd Parity

TCP/IP Interface. The Ethernet (TCP/IP) interface is most often used with host computers communicating over a local area network (LAN). You must use Telesis Extended Protocol with the TCP/IP interface.

The Port parameter identifies the host computer socket that is assigned to the marking system. If more than one marking system is installed in a network configuration, each system must use a separate and unique port number. The Address parameter identifies the IP address of the host computer. The marking system software supports both fixed addressing and dynamic addressing.

Optionally, the Ethernet Port may be connected to a PC running the Merlin III Visual Design Software. Any computer that runs the Merlin III software must satisfy the following requirements:

- Windows® 2000 or Windows® XP or Windows® Vista™ Business Operating System
- Pentium® 4 Processor
- Sufficient RAM as per Operating System Requirements
- Video Board
- Multi-Gigabyte Hard Drive
- CD-ROM Disk Drive
- One Available Ethernet Port (minimum)
- SVGA Color Monitor, Mouse, and Keyboard

Programmable Protocol. Use this protocol where very simple one-way communications are required (such as with bar code scanners). Programmable Protocol provides no error checking or acknowledgment of the transmitted data. Note that XON/XOFF Protocol applies even when Programmable Protocol is selected.

Starting Character specifies where the software begins to count character positions. This number must be entered in ASCII decimal format such as 2 for STX.

Terminating Character identifies the end of transmitted string (usually ASCII carriage return character, decimal 13).

Character Position counted from the starting character ignoring all characters preceding it.

Character Length accepts variable length messages (if set to 0) or messages of a pre-specified, fixed number of characters.

Ignore Character identifies the character to ignore when sent from the host (usually ASCII line feed character, decimal 10).

Message Type allows message-type recognition which defines how the marking system will use data it receives from the host.

49 (Type 1) overwrites first text field with data extracted from the host

80 (Type P) loads a specific pattern identified by data extracted from host

81 (Type Q) updates text in first query buffer with data extracted from host

86 (Type V) updates first variable text field with data extracted from host

0 (Type Zero) indicates that host will provide message type, field number (if applicable), and data; delegates message type selection to the host on message-by-message basis. The host message must use the format

Tnn<string> where:

T = 1, P, Q, or V to indicate the message type.

nn = two-digit number to indicate field number or query text buffer where data will be placed. Note that a number is not used with Message Type P.

<string> = field data (Message Types 1, Q, or V) or pattern name (Message Type P), as applicable.

Extended Protocol. This protocol selection includes error checking and transmission acknowledgment. It should be used in applications where serial communication is a vital part of the marking operation. All communications are carried out in a parent/child relationship with the host being the parent. Only the host has the ability to initiate communications. If the host does not receive a response within three seconds, it should re-transmit its original message. If no response is received after three tries, it should declare the link to be down.

The following describes the Extended Protocol message format as sent from the host to the TMC090 controller.

SOH TYPE [##] STX [DATA TEXT] ETX BCC CR

SOH ASCII Start of Header character (001H). The controller ignores all characters received prior to the SOH.

TYPE A single, printable ASCII character that defines the meaning (type) and content of the message downloaded from the host, where:

- 1** Message Type 1 overwrites specified field of currently loaded pattern, using the data format **nn<string>** where nn is the field number.
- P** Message Type P specifies pattern name to be loaded for printing
- Q** Message Type Q updates specified query buffer with data received from host, using the data format **nn<string>** where nn is the buffer number.
- V** Message Type V updates specified variable text field of currently loaded pattern, using the data format **nn<string>** where nn is the field number.
- O** Message Type O resets marker and places it online
- G** Message Type G initiates a print cycle to mark the currently loaded pattern
- I** Message Type I requests the marker return the status of standard output and input signals. The system will return a hexadecimal code for the 6 output signals and 12 input signals in the following format:

OO;IIII

where:

bit 1	READY	0x01
bit 2	DONE	0x02
bit 3	PAUSED	0x04
bit 4	NO_FAULT	0x08
bit 5	SPARE_1	0x10
bit 6	SPARE_2	0x20
bit 1	START	0x001
bit 2	STOP	0x002
bit 3	SEL_0	0x004
bit 4	SEL_1	0x008
bit 5	SEL_2	0x010
bit 6	SEL_3	0x020
bit 7	SEL_6 *	0x040
bit 8	SEL_4	0x080
bit 9	SEL_5	0x100
bit 10	SPARE_1	0x200
bit 11	SPARE_2	0x400
bit 12	SPARE_3	0x800

* Input bit 6 * may be configured to place machine online (default) or for Remote Pattern Selection.

[##] Two optional ASCII decimal digits that specify the Station ID number for use in multi-drop network applications. The ID may range from 00-31. Note that "00" is reserved for applications where only one controller is used. In such applications, this field may be eliminated and "00" will be assumed.

STX ASCII Start of Text Character (002H).

[DATA TEXT] Optional character string that may be required for certain message types (e.g., Type 1, P, Q, and V).

ETX ASCII end of text character (003H).

BCC Optional Block Check Code that is generated and sent to improve link reliability by providing fault detection. The BCC is calculated by taking an eight bit addition of the TYPE and DATA TEXT characters and transmitting them as a three digit ASCII decimal number in the range from 000 to 255. If the sum is greater than 255, the most significant bit overflows and is discarded.

CR ASCII Carriage Return Character (00DH).

TRADEMARKS

Telesis, **PINSTAMP**, and **Merlin** are registered trademarks of Telesis Technologies, Inc. in the United States.

MicroPin is a trademark of Telesis Technologies, Inc. in the United States.

NEMA is the registered trademark and service mark of the National Electrical Manufacturers Association.

Pentium is a registered trademark of Intel Corporation in the United States and other countries.

Vista is a trademark of Microsoft Corporation in the United States and other countries.

Windows is a registered trademark of Microsoft Corporation in the United States and other countries.