

System Overview

The Telesis® TMP3200/470 PINSTAMP® marking system permanently prints messages into a variety of materials such as steel, aluminum, and plastic. A hardened pin is pneumatically accelerated to indent dot matrix characters into the item being marked. The shape, size, density, and location of characters are determined by the user through the system software. The marking head moves the pin cartridge through X- and Y-axis motions to reach the correct position for each dot of the characters to be marked. The system software automatically controls pin extension and retraction to mark the message.

The system is compliant with UL, CSA, CE, and RoHS specifications.

TMP3200 Marking Head includes the mechanical motion components to position the marking pin at precise X/Y positions and the pneumatic components to drive the marking pin out from, and return the pin back into, the pin cartridge.

The TMP3200 marking head is an X/Y-traversing mechanism. Using two stepper motor drives, it accurately and rapidly positions the pin at coordinate-defined locations in marking window within .03175 mm (.00125"). The marker accommodates the rigorous dynamics of impacting, rebounding, and rapid positioning of the marking pin through a system of rigid rails and ball bearing saddles, timing belts, and direct-drive, toothed pulleys.

The floating pin design permits high quality, consistent marks on irregular, slightly curved surfaces. It also accommodates applications where marking surfaces cannot be positioned at a consistent distance from the marker.

The internal mechanism is protected from debris by an integral shield. Stainless steel panels slide against one another, constrained

by the cartridge and the high-impact ABS cover, to prevent debris from entering the marking head.

Marker Cable, pre-wired to the marking head, connects the marker to the controller. The highly flexible cable is 4m (13 ft.) long. Optional extension cables are available for greater distances.

Marking Pins for the TMP3200 include the 25S-, 25L-, 25XL, and the 150SA-series. Refer to the marking head installation drawing for pin stroke (pin extension) dimensions. Refer to the marking depth tables for pin cone angles and depths.

Filter/Regulator Unit includes two regulators with pressure gauges to control the drive air and return air. The first regulator contains a filter to help remove contaminants from the supply air. Two air lines connect the regulated air to the marking head. Drive air fires the impact pin; return air pushes it back into the cartridge. The standard air lines are 4m (13 ft.) long made of 6 mm tubing.

TMC470 Controller contains an integrated keyboard with an LCD display. It provides a text-only operator interface and allows full operational control of the TMP3200 marking head. The back panel provides the electrical interface for connecting to optional, remote I/O sources. Refer to *TMC470 Controller Specifications* for details.

Optional System Computer. The TMC470 Controller may be connected to a PC that runs the Merlin® III Visual Design Software. The PC may be supplied by Telesis or by the customer. Refer to *PC-based Merlin III Software* and *TCP/IP Interface* for details.

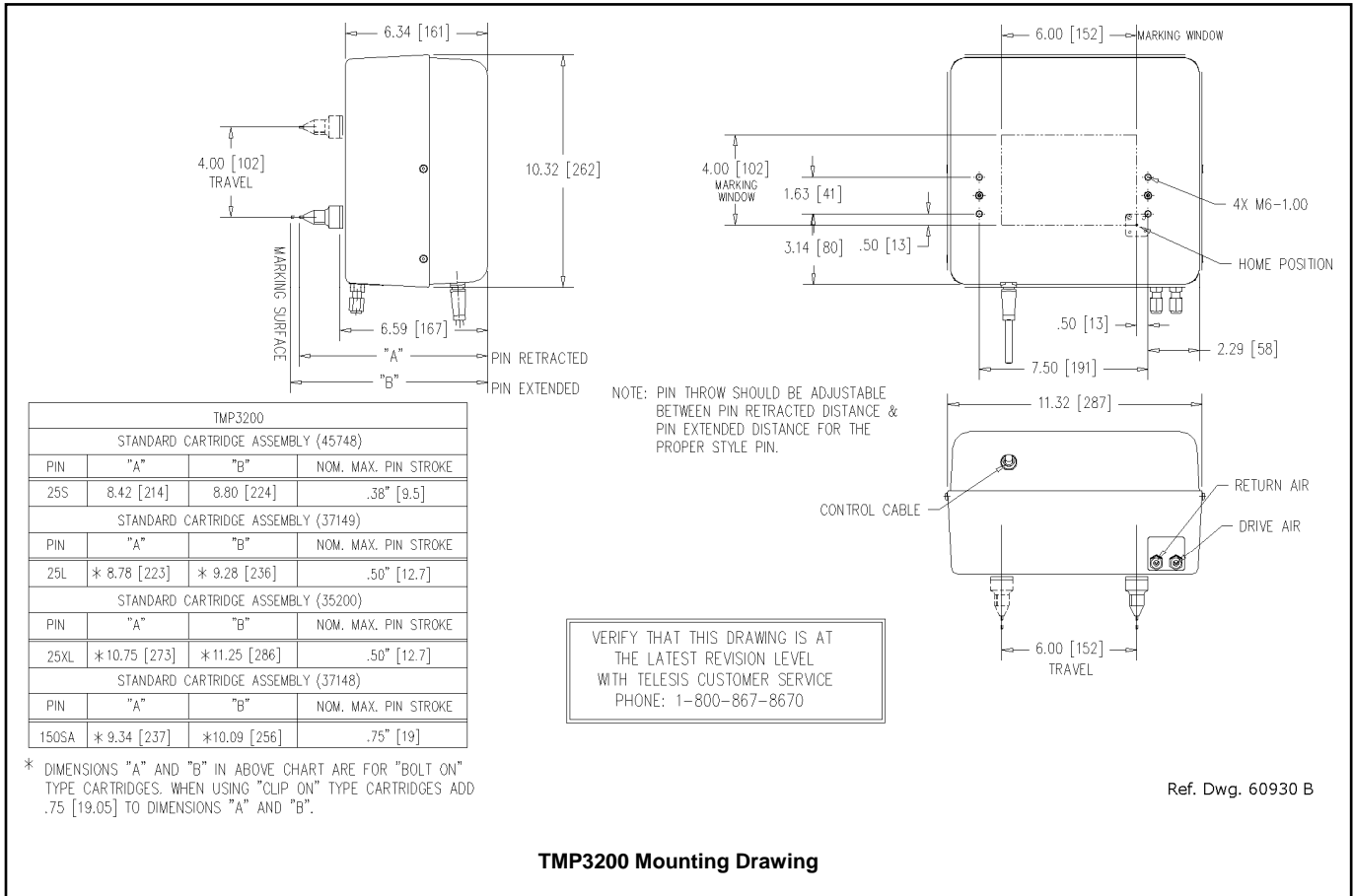

TMP3200 Mounting Drawing

System Setup

When designing a fixture, allow for 3-axis adjustment to aid in horizontal, vertical, and lateral alignment of the marking head.

- Mount marking head to optional tool post assembly (or other suitable fixture) using four M6-1.00 x 20 mm bolts.
Note: The marking head may be mounted in any orientation, but preferred installation is with the pin pointed *downward*.
- Mount filter/regulator assembly within 12 ft. (3.6m) of marker.
- Connect drive air and return air lines to the marking head.
- Connect supply air to input port on filter/regulator assembly.

Note: The TMC470 is not a sealed unit. Protect it from potentially damaging conditions and contaminants. Do not block vents in bottom of case. Ensure the marking system is electrically isolated from any devices that may generate extreme electromagnetic interference (EMI).

- Locate controller as close as practical to marking head. Standard marker cable length is 4 m (13 ft.).

- Install the controller as a table-top, wall-mounted, panel-mounted, or enclosure-mounted unit, as applicable.
- Ensure controller power switch is OFF.
- Connect marker cable to controller.
- Connect power cable to controller.
- (optional) For systems that connect to a PC running the Merlin III Visual Design Software:
 - Ensure PC power switch is OFF.
 - Connect cable to controller Ethernet Port and to PC.
 - Connect power cable to PC.
 - Position PC power switch to ON.
 - (customer-supplied PC) Install marking system software.
- Position controller power switch to ON.
- Start marking system software.
- Adjust pin stroke, drive air, and return air for impact depth.

System Options

- Tool Post Assembly
- Clip-on Cartridge Adapter Kit
- Marking Head Extension Cables
- Auxiliary Axis Driver Board Kit
- Motorized Z-axis Tool Post with Programmable Travel
- Motorized Theta-axis with Programmable Rotary Drive Unit
- TMC470 Controller Wall-mounting Bracket Kit
- TMC470 Controller Panel-mounting Bezel/Bracket Kit
- TMC470N NEMA® Enclosure
- Bar Code Scanner or Bar Code Wand with Cable
- Foot Switch (Start Print) or Pushbutton Station (Start/Abort)
- Backup Utility Software
- Upgrade Utility Software
- Logo/Font Generator Software
- Merlin III Visual Design Software
- System Computer (to run the Merlin III software)

TMP3200 Marking Head

Specifications. The TMP3200 marking head specifications are subject to change without prior notice.

| | |
|------------------------|---|
| DIMENSIONS | <i>see TMP3200 Mounting Drawing</i> |
| WEIGHT | 6.8 kg (15 lb.), marking head and cable |
| OPERATING TEMP. | 0° to 50° C (32° to 122° F), non-condensing |
| AIR SUPPLY | Clean and dry, 4.0 to 6.9 bars (60 to 100 psi) |
| AIR CONSUMPTION | 0.04 SCFM (idle) 0.8 SCFM (marking) |
| MARKING AREA | 150 x 100 mm (6.0 x 4.0") |
| PIN TYPES | 25S-, 25L-, 25XL-, or 150SA-series |
| PIN MATERIAL | Powdered metal or stainless steel with diamond tip or carbide (25S, 25L, 25XL-series) Powdered metal or tool steel with carbide tip (150SA-series) |

Pin Life. Pin life depends largely on the type of material being marked, how hard or abrasive it is, and the required marking depth. On typical metals with a hardness of Rockwell Rb47, marking at a depth of .127 mm (.005"), powdered steel pins average about 3 million impressions before needing sharpened; carbide pins average approximately 9 million impressions. If carbide pins are used, marking times will increase by approximately 25% due to the increased weight of the pins.

Marking Characteristics. The TMP3200 can produce characters as small as .76 mm (.030"), printed at any angle within the marking window. Printing resolutions range from 4 to 79 dots per cm (10 to 200 dots per inch) for an engraved look. The depth of mark can be adjusted over a significant range by adjusting the pin stroke and, to a lesser extent, by adjusting the drive air pressure.

Marking Speeds. The system will mark up to four characters per second when marking 3 mm (.118 in.) high, 5 x 7 dot matrix characters using a 25S powdered steel marking pin with the

standard 25S cartridge, with a pin stroke of 3 mm (.118 in.) and the drive air pressure set to 5.5 bars (80 psig). The marking speed can be adjusted to allow more precisely formed characters. Doing so, under these same conditions, will result in reduced marking speeds. Note that marking speeds vary widely depending on character size, drive air pressure, dot density, pin stroke, pin type and pin cartridge. Increased character size, increased dot density, increased pin stroke, and/or decrease drive air pressure all result in decreased marking speeds. The use of a heavier marking pin, such as the 25S carbide pin or the 150SA carbide-tipped pin, or the use on non-standard marking pin cartridges will also result in decreased marking speeds. Specific times and speeds can be verified by a Telesis representative.

Marking Noise. Although every attempt is made to reduce noise, the material being marked significantly influences the noise level. For example, marking a solid lead block produces less noise than marking a thin-walled steel pipe.

Marking Depth. The following tables provide sample marking depths. Drive air was set at 5.5 bars (80 psi); return air was set at 1.5 bars (20 psi); pin stroke was set to the maximum allowable distance for each pin type to achieve the maximum depth of mark.

Max. Marking Depths – Type 25S Powdered-Metal Pin

| MATERIAL (HARDNESS) | 30° CONE | 45° CONE | 60° CONE |
|--------------------------|---------------------|---------------------|---------------------|
| Aluminum (Rb2) | .178 mm .007 in. | .229 mm .009 in. | .279 mm .011 in. |
| Brass (Rb22) | .152 mm .006 in. | .178 mm .007 in. | .203 mm .008 in. |
| Cast Iron (Rb47) | .127 mm .005 in. | .152 mm .006 in. | .178 mm .007 in. |
| Cold Rolled Steel (Rb53) | .102 mm .004 in. | .127 mm .005 in. | .152 mm .006 in. |

Max. Marking Depths – Type 25S Carbide Pin

| MATERIAL (HARDNESS) | 30° CONE | 45° CONE | 60° CONE |
|--------------------------|---------------------|---------------------|---------------------|
| Aluminum (Rb2) | .178 mm .007 in. | .229 mm .009 in. | .305 mm .012 in. |
| Brass (Rb22) | .152 mm .006 in. | .203 mm .008 in. | .254 mm .010 in. |
| Cast Iron (Rb47) | .127 mm .005 in. | .178 mm .007 in. | .203 mm .008 in. |
| Cold Rolled Steel (Rb53) | .102 mm .004 in. | .152 mm .006 in. | .178 mm .007 in. |

Max. Marking Depths – Type 150SA Carbide-Tipped Pin

| MATERIAL (HARDNESS) | 30° CONE | 45° CONE |
|--------------------------|---------------------|---------------------|
| Aluminum (Rb2) | .356 mm .014 in. | .457 mm .018 in. |
| Brass (Rb22) | .229 mm .009 in. | .330 mm .013 in. |
| Cast Iron (Rb47) | .203 mm .008 in. | .279 mm .011 in. |
| Cold Rolled Steel (Rb53) | .203 mm .008 in. | .254 mm .010 in. |

TMP3200/470 Marking System

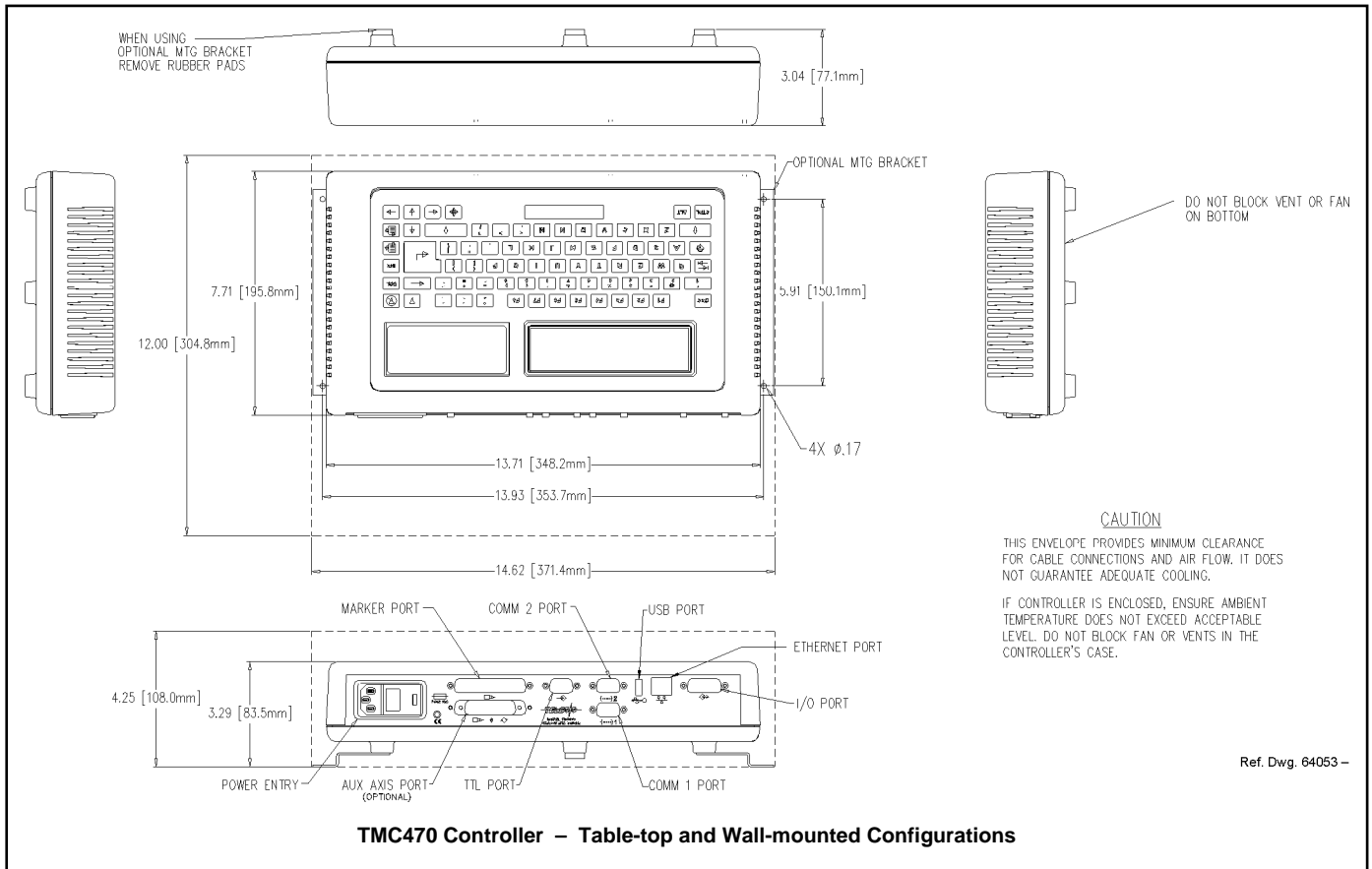

TMC470 Controller

The TMC470 controller may be installed as a table-top unit, a wall-mounted unit, a panel-mounted unit, or an enclosure-mounted unit. All configurations provide features and connectivity for external communications. Differences occur only in the mounting configuration.

TMC470 Specifications. The TMC470 Controller specifications are subject to change without prior notice.

| | |
|-----------------------|---|
| COMPLIANCE | CE, RoHS |
| CONFIGURATIONS | Table-top, Wall-mounted, Panel-mounted, or Enclosure-mounted |
| RATING | NEMA 1 (I.P. 30) table-top or wall-mounted NEMA 12 (I.P. 65) panel-mounted using appropriate customer-supplied panel NEMA 12 (I.P. 65) enclosure-mounted using Telesis-supplied TMC470N enclosure |
| DIMENSIONS | refer to the TMC470 Mounting Drawings |
| WEIGHT | 3.69 lb. (1.68 kg) controller only 3.90 lb. (1.77 kg) with wall-mount kit 5.52 lb. (2.51 kg) with panel-mount kit 28.1 lb. (12.77 kg) with TMC470N enclosure |

TMC470 Specifications (continued)

| | |
|------------------------|---|
| OP. TEMPERATURE | 32° to 122° F (0° to 50°C) |
| OP. HUMIDITY | 10% to 80% non-condensing |
| COOLING | Internal, thermostatically-controlled fan |
| POWER REQ'MENTS | 95 to 250 VAC, 2 amps, 50-60 Hz, single phase |
| COMMUNICATIONS | TTL, Discrete I/O, RS232, RS485, TCP/IP, and USB (data backup/transfer) |
| INPUT SIGNALS | Twelve (12) total 8 dedicated, 1 programmable, 3 available 10 VDC (minimum voltage) 30 VDC (maximum voltage) 12 to 24 VDC (nominal voltage) 2.3 mA @ 12VDC; 4.9 mA @ 24VDC (nominal current) |
| OUTPUT SIGNALS | Six (6) total 4 dedicated, 2 available 0.25 amps (maximum current) 0.50 ohms (maximum On resistance) 40 VDC (maximum line voltage) 12 to 24 VDC (nominal line voltage) |

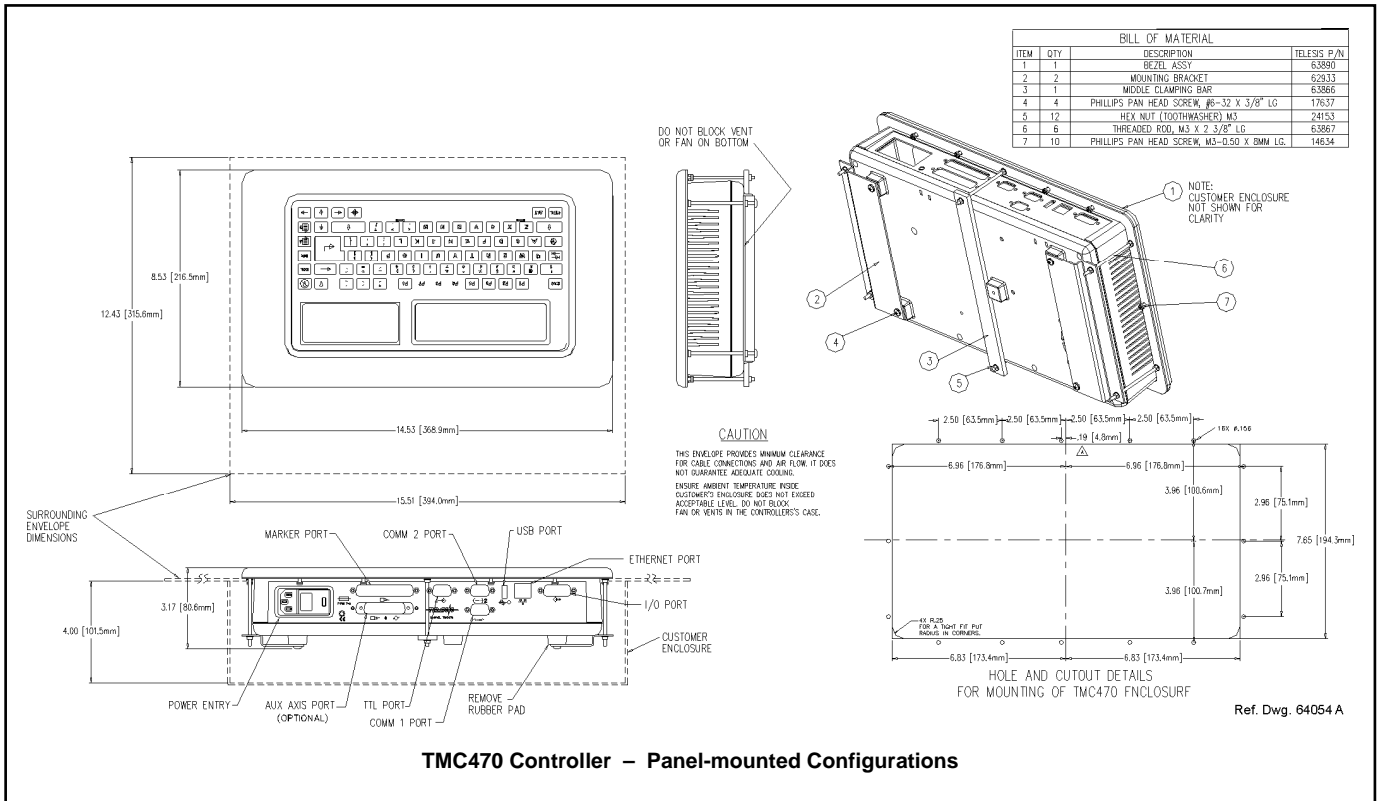

TMC470 Controller – Panel-mounted Configurations

Environmental Considerations. The following environmental considerations must be taken into account when installing the TMC470 Controller.

Contaminants. The vented TMC470 is rated NEMA 1 (IP30) and contains a thermostatically-controlled, variable speed fan. Accordingly, in environments where solid and/or liquid contaminants are present, the possibility exists that these contaminants can be drawn into the TMC470 controller and possibly result in failure. For that reason, in these types of environments, the controller must be located in a sealed industrial enclosure. To facilitate such installations, Telesis offers an optional panel mounting kit for use with an appropriate customer-supplied panel or enclosure. Telesis also offers an optional TMC470N NEMA 12 (I.P. 65) enclosure in which the controller can be mounted.

EMI Susceptibility. Although the system has been found to be in compliance with pertinent susceptibility standards, care should be taken when installing near welders and other extreme generators of electromagnetic interference (EMI). Particular care should be taken to ensure welder currents are not injected through the marking head chassis. The marking head chassis is connected to the electrical service earth ground through the marking head cable. The marking head should be electrically isolated from all surfaces which could become part of a welder current path.

TMC470-based System Software. The system software is permanently installed in the controller. It provides the user interface for the operator to control the marker. The software also provides a library for storing, loading, and editing user-defined patterns. Patterns are files stored in the controller's memory. Depending on the size of the pattern files, the controller can store up to 200 patterns. Each pattern contains one or more fields; each field defines a single object. Printable objects may be created to define text strings, arc-text strings, geometric shapes, graphics, and machine-readable data matrix symbols. Non-printable objects may be defined to specific commands to the marker (e.g., Pause, Go to, Input, or Output). Printable text fields may include alphanumeric characters, symbols, and special message flags. Message flags automatically insert data into the text string, such as serial numbers, times, dates and user-defined codes.

PC-based Merlin III Visual Design Software. Optionally, the TMC470 Controller may be connected to a PC that runs the Telesis Merlin III Visual Design Software. The software is a 32-bit Windows® based WYSIWYG application that provides a graphical user interface to make pattern design quick and easy. Just "click and drag" for immediate adjustment to field size, location, or orientation. The Merlin III software includes tools to create and edit text, arc text, rectangles, circles, ellipses, and lines. Existing DXF files can also be imported for marking.

After downloading patterns to the controller, the PC can be disconnected from the controller to allow the TMC470 to control marking operations. Optionally, the PC may remain connected to the controller and allow the Merlin III software to fully control the marking system.

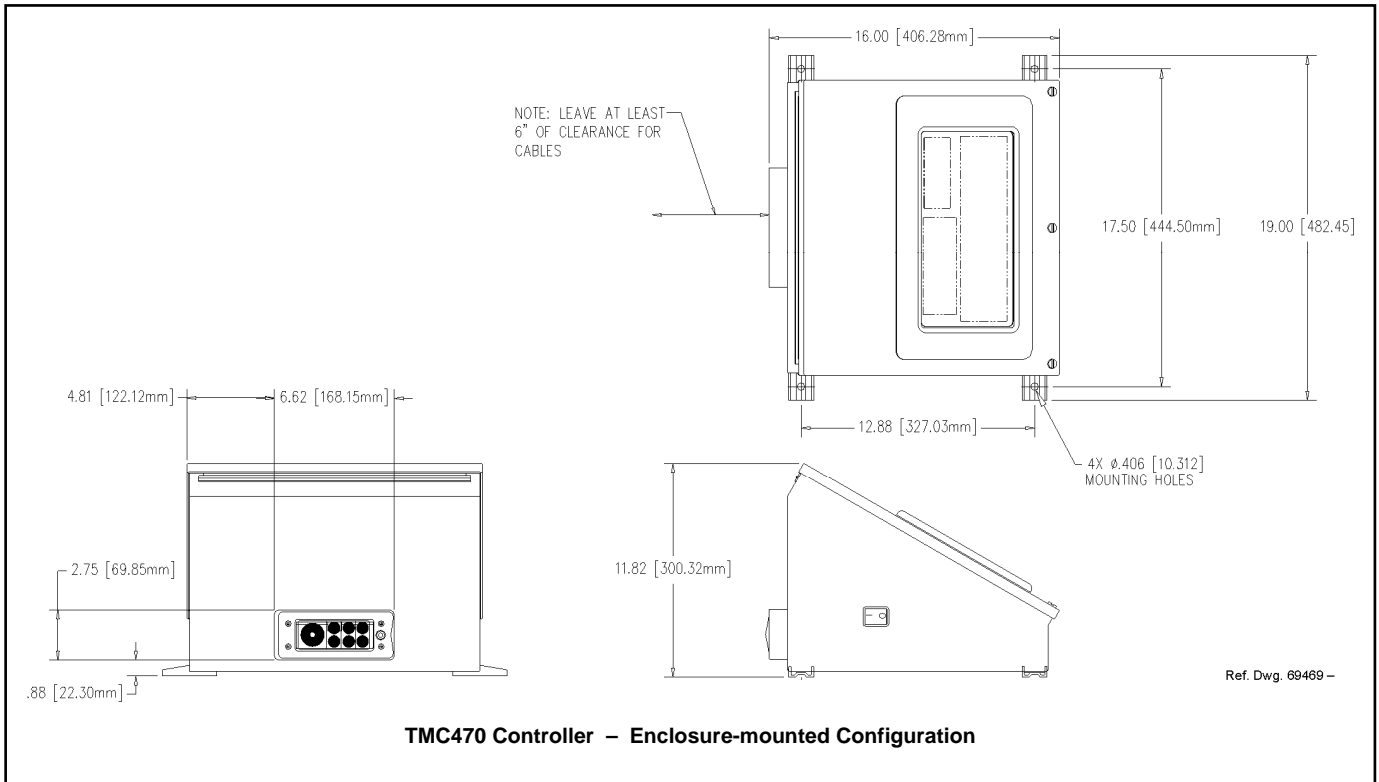

Interface Panel. The back panel of the controller provides various ports for connecting the marker, host computers, logic controllers, optional accessories, and remote I/O devices. See below.

- **Serial Interface.** The Comm 1 and Comm 2 Ports allow connection to remote serial devices such as a host computer or a bar code scanner. See *Host Communications* for details.
- **Discrete I/O Interface.** The I/O Port allows you to connect a Programmable Logic Controller (PLC) or other DC I/O source for remotely controlling marker operations. See *Discrete I/O Controls* for details.
- **TTL Interface.** The TTL Port allows the system to connect with a simple contact closure circuit such as a remote push button station or foot pedal switch. These types of devices can remotely control Start Print and Stop Print operations.
- **TCP/IP Interface.** The Ethernet Port typically connects to a PC over a local area network (LAN). It allows you to define the controller as a client or a server socket using Telesis Extended Protocol. See *Host Communications* for details.
- **USB Interface.** The USB Port allows you to connect a memory stick/flash drive for pattern storage/retrieval and for software upgrades.
- **(optional) Auxiliary Axis Interface.** The Auxiliary Axis Port allows the system to connect with up to four optional motion devices such as motorized tool posts, rotational drive units, and linear slides or actuators.

Discrete I/O Controls

The TMC470 is configured for 12 VDC to 24 VDC I/O only and is provided to connect a PLC or other DC I/O source. The I/O Port allows you to remotely select and load patterns, start printing, stop printing, place the marker online, and monitor the system output signals. Cable connectors and connector pins are supplied with the controller for constructing appropriate interface cables.

Input Signals. These input signals provide the following controls:

| | |
|------------------------|--|
| INPUT COMM | For all inputs (+ or – supply) |
| START PRINT | Begins print cycle |
| STOP | Stops the print cycle |
| SEL_0 THRU _6 * | Remotely selects and loads pattern files |
| SPARE_1, 2, 3 | Three (3) spares for custom applications |

* Optionally, the SEL_6 signal may be programmed to place the marker online.

Output Signals. These output signals indicate the following states:

| | |
|--------------------|--|
| OUTPUT COMM | For all outputs (+ or – supply) |
| DONE | Print cycle is complete |
| READY | System ready for message or start print |
| PAUSED | System paused (waiting timeout or command) |
| NO FAULT | System status (normal or fault detected) |
| SPARE_1, 2 | Two (2) spares for custom applications |

Host Communications

The marking system software allows you to configure communication parameters to transmit and receive data to and from a host computer. To provide maximum integration flexibility, the system software supports RS-232 and RS-485 serial interfaces and Ethernet TCP/IP interfaces. The system software also provides two protocol choices: Programmable Protocol and Extended Protocol.

RS-232 Interface. The serial (RS-232) communications interface is most often used with remote devices such as host computers, terminals, or bar code scanners. The Comm 1 RS-232 interface supports both Telesis Extended Protocol and Telesis Programmable Protocol. The Comm 2 RS-232 interface supports only Telesis Programmable Protocol.

RS-485 Interface. The RS-485 interface is normally used for long transmission distances or multi-drop networks of up to 31 TMC470 controllers. You must use Telesis Extended Protocol with the RS-485 interface.

The following describes the serial data character format on all transmissions to and from the TMC470 Controller.

- Asynchronous
- 1200, 2400, 4800, 9600, 19200, 38400, or 115200 Baud
- 1 or 2 Stop Bits
- 7 or 8 Data Bits
- None, Even or Odd Parity

TCP/IP Interface. The Ethernet (TCP/IP) interface is most often used with host computers communicating over a local area network (LAN). You must use Telesis Extended Protocol with the TCP/IP interface.

The Port parameter identifies the host computer socket that is assigned to the marking system. If more than one marking system is installed in a network configuration, each system must use a separate and unique port number. The Address parameter identifies the IP address of the host computer. The marking system software supports both fixed addressing and dynamic addressing.

Optionally, the Ethernet Port may be connected to a PC running the Merlin III Visual Design Software. Any computer that runs the Merlin III software must satisfy the following requirements:

- Windows® 2000 or Windows® XP or Windows® Vista™ Business Operating System
- Pentium® 4 Processor
- Sufficient RAM as per Operating System Requirements
- Video Board
- Multi-Gigabyte Hard Drive
- CD-ROM Disk Drive
- One Available Ethernet Port (minimum)
- SVGA Color Monitor, Mouse, and Keyboard

Programmable Protocol. Use this protocol where very simple one-way communications are required (such as with bar code scanners). Programmable Protocol provides no error checking or acknowledgment of the transmitted data. Note that XON/XOFF Protocol applies even when Programmable Protocol is selected.

Starting Character specifies where the software begins to count character positions. This number must be entered in ASCII decimal format such as 2 for STX.

Terminating Character identifies the end of transmitted string (usually ASCII carriage return character, decimal 13).

Character Position counted from the starting character ignoring all characters preceding it.

Character Length accepts variable length messages (if set to 0) or messages of a pre-specified, fixed number of characters.

Ignore Character identifies the character to ignore when sent from the host (usually ASCII line feed character, decimal 10).

Message Type allows message-type recognition which defines how the marking system will use data it receives from the host.

49 (Type 1) overwrites first text field with data extracted from the host

80 (Type P) loads a specific pattern identified by data extracted from host

81 (Type Q) updates text in first query buffer with data extracted from host

86 (Type V) updates first variable text field with data extracted from host

0 (Type Zero) indicates that host will provide message type, field number (if applicable), and data; delegates message type selection to the host on message-by-message basis. The host message must use the format

Tnn<string> where:

T = 1, P, Q, or V to indicate the message type.

nn = two-digit number to indicate field number or query text buffer where data will be placed. Note that a number is not used with Message Type P.

<string> = field data (Message Types 1, Q, or V) or pattern name (Message Type P), as applicable.

Extended Protocol. This protocol selection includes error checking and transmission acknowledgment. It should be used in applications where serial communication is a vital part of the marking operation. All communications are carried out in a parent/child relationship with the host being the parent. Only the host has the ability to initiate communications. If the host does not receive a response within three seconds, it should re-transmit its original message. If no response is received after three tries, it should declare the link to be down.

The following describes the Extended Protocol message format as sent from the host to the TMC090 controller.

SOH TYPE [##] STX [DATA TEXT] ETX BCC CR

SOH ASCII Start of Header character (001H). The controller ignores all characters received prior to the SOH.

TYPE A single, printable ASCII character that defines the meaning (type) and content of the message downloaded from the host, where:

- 1** Message Type 1 overwrites specified field of currently loaded pattern, using the data format **nn<string>** where nn is the field number.
- P** Message Type P specifies pattern name to be loaded for printing
- Q** Message Type Q updates specified query buffer with data received from host, using the data format **nn<string>** where nn is the buffer number.
- V** Message Type V updates specified variable text field of currently loaded pattern, using the data format **nn<string>** where nn is the field number.
- O** Message Type O resets marker and places it online
- G** Message Type G initiates a print cycle to mark the currently loaded pattern
- I** Message Type I requests the marker return the status of standard output and input signals. The system will return a hexadecimal code for the 6 output signals and 12 input signals in the following format:

00;IIII

where:

| | | |
|--------|----------|-------|
| bit 1 | READY | 0x01 |
| bit 2 | DONE | 0x02 |
| bit 3 | PAUSED | 0x04 |
| bit 4 | NO_FAULT | 0x08 |
| bit 5 | SPARE_1 | 0x10 |
| bit 6 | SPARE_2 | 0x20 |
| bit 1 | START | 0x001 |
| bit 2 | STOP | 0x002 |
| bit 3 | SEL_0 | 0x004 |
| bit 4 | SEL_1 | 0x008 |
| bit 5 | SEL_2 | 0x010 |
| bit 6 | SEL_3 | 0x020 |
| bit 7 | SEL_6 * | 0x040 |
| bit 8 | SEL_4 | 0x080 |
| bit 9 | SEL_5 | 0x100 |
| bit 10 | SPARE_1 | 0x200 |
| bit 11 | SPARE_2 | 0x400 |
| bit 12 | SPARE_3 | 0x800 |

* Input bit 6 * may be configured to place machine online (default) or for Remote Pattern Selection.

[##] Two optional ASCII decimal digits that specify the Station ID number for use in multi-drop network applications. The ID may range from 00-31. Note that "00" is reserved for applications where only one controller is used. In such applications, this field may be eliminated and "00" will be assumed.

STX ASCII Start of Text Character (002H).

[DATA TEXT] Optional character string that may be required for certain message types (e.g., Type 1, P, Q, and V).

ETX ASCII end of text character (003H).

BCC Optional Block Check Code that is generated and sent to improve link reliability by providing fault detection. The BCC is calculated by taking an eight bit addition of the TYPE and DATA TEXT characters and transmitting them as a three digit ASCII decimal number in the range from 000 to 255. If the sum is greater than 255, the most significant bit overflows and is discarded.

CR ASCII Carriage Return Character (00DH).

TRADEMARKS

Telesis, **PINSTAMP**, and **Merlin** are registered trademarks of Telesis Technologies, Inc. in the United States.

NEMA is the registered trademark and service mark of the National Electrical Manufacturers Association.

Pentium is a registered trademark of Intel Corporation in the United States and other countries.

Vista is a trademark of Microsoft Corporation in the United States and other countries.

Windows is a registered trademark of Microsoft Corporation in the United States and other countries.